

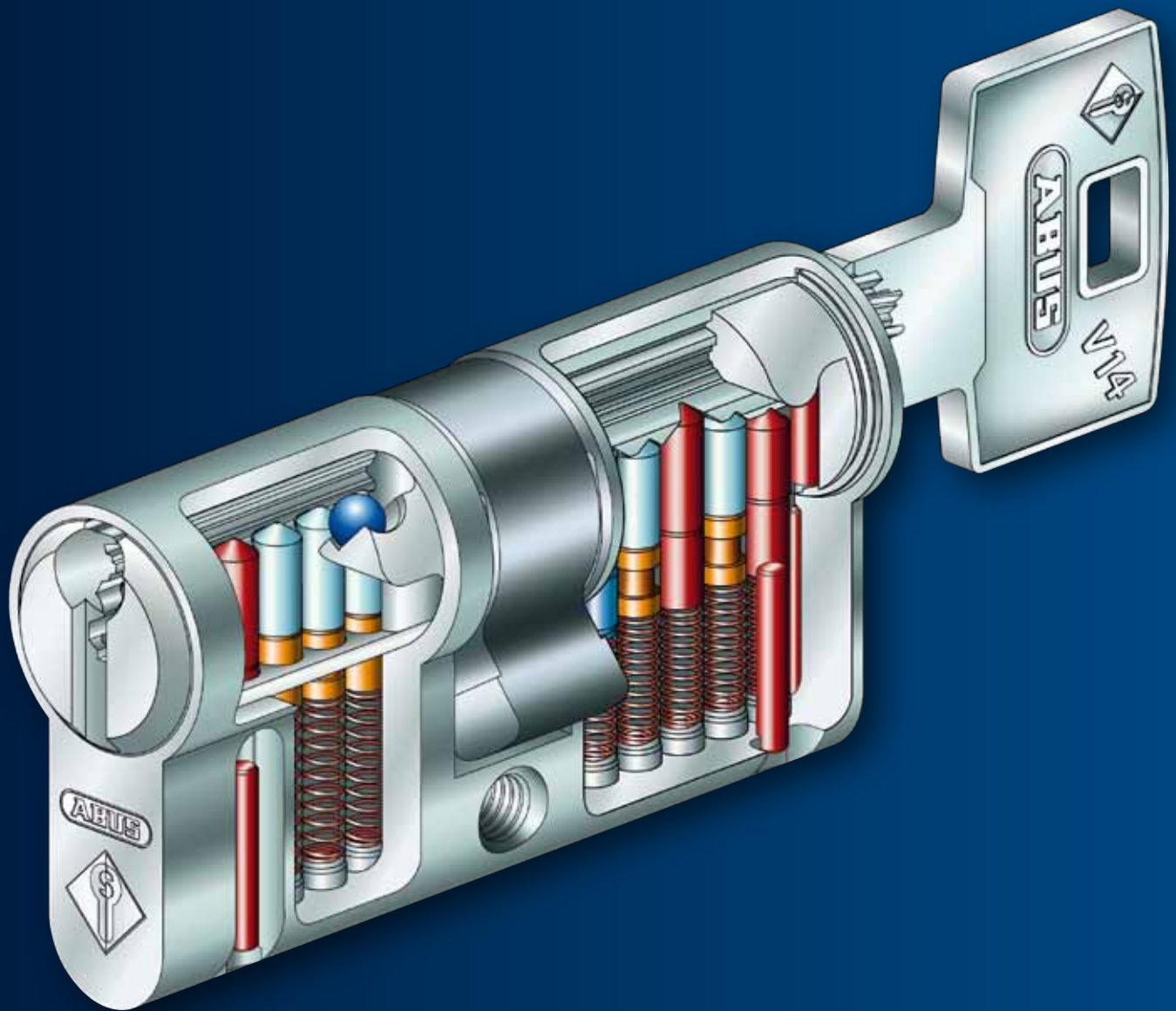

Security Tech Germany

System V14

Bent precision profile with coded rib



MADE IN GERMANY

Multiple paracentric profile with bent precision

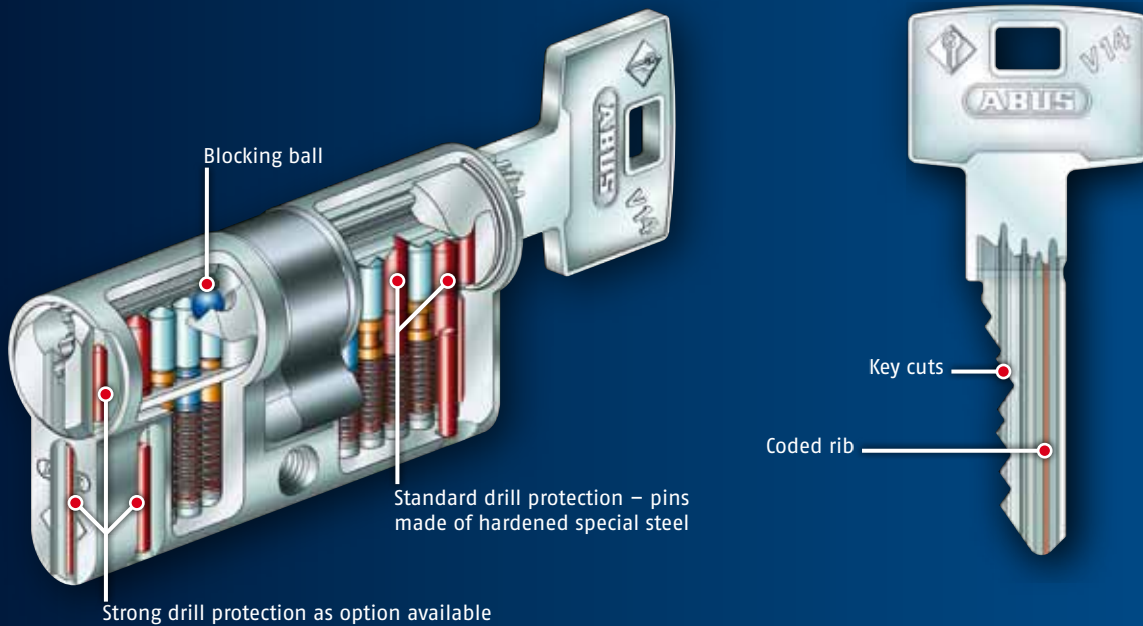

Cylinder illustration with optional drill protection

Coded rib with blocking ball

- The blocking ball blocks in case of manipulation attempts (eg. picking)
- If the key is not cut correctly or does not contain the coded rib, the blocking ball will avoid the opening of the cylinder



Bent precision profile

- The bent precision profile offers an effective picking resistance
- This special profile shape offers a high protection against key copying
- The bent shape gives the key an explicit higher stability



General system advantages

- Complex locking because of a 14 mm core diameter
- Can be combined with systems of higher security levels (XV14 or KV14)
- Legal protection against copying (patent)
- Emergency feature available from length 26,5/26,5 mm onwards
- VdS class B in 6 pin cylinders as option available
- Production according to DIN EN 1303, DIN18252 and ISO 9001:2008
- 5 or 6 pins per cylinder side



Security Tech Germany

International product range

America locks in a different way than Germany. Asia locks differently than Europe. When it comes to the variety of products we take each challenge and answer it with our international solutions: "Made in Germany."



Special features for your individual locking system

Drill and pull protection

Different options are available

Pre-snap function

For the controlled breaking of the cylinder at a predetermined breaking point

VdS approval

For locking systems and individual cylinders which are especially relevant for insurance claims



Electronic locking system

Can be combined with the electronic locking system of the ABUS group

Emergency feature

Locking of the cylinder from one side even when a key is inserted in the other side

Emergency feature with free-wheel cam

For mortise locks with a panic feature and multi-point locking

Salt water resistant cylinders

Corrosion resistance according to DIN 50 021-SS

Further special features

Of course, other special features are available as well

Please contact us



Security Tech Germany

Combination with system XV14 (optional) For a higher protection against illegal opening

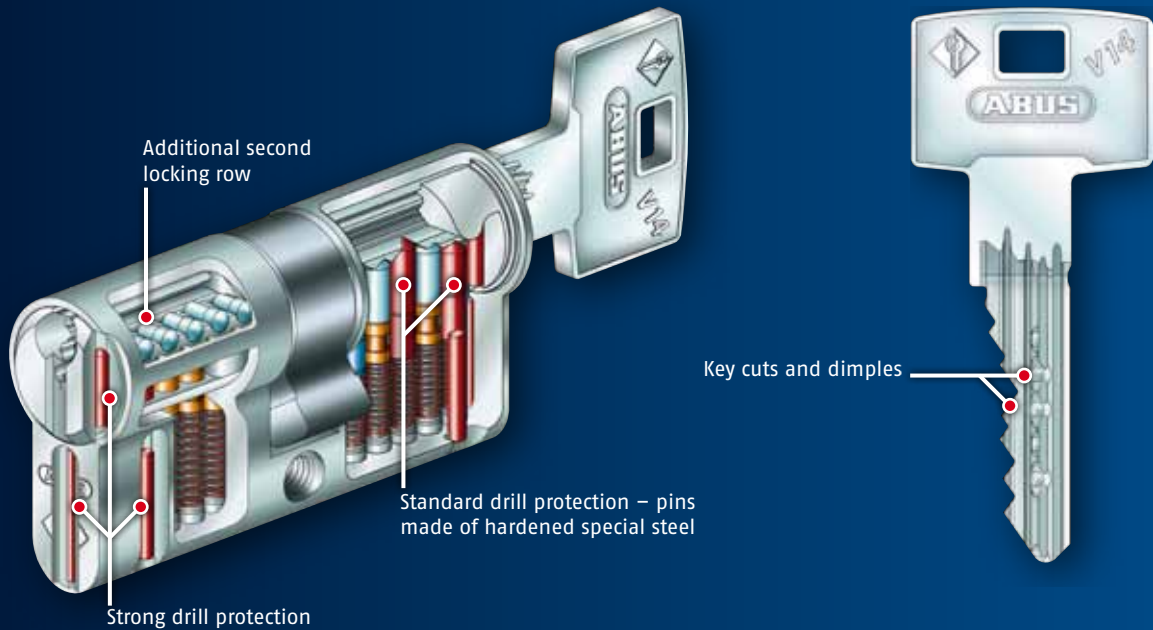

Cylinder illustration with optional drill protection

Ideal complement for higher security demands

- System XV14 = System V14 + passive lateral locking elements (X14)
- The second locking row (XV14) extends the authority request and makes manipulation more complicated
- The extension to XV14 can be used for a whole key system or only for parts of it which are more relevant for higher security demands

Improved safety

- An additional row of pins makes intelligent manipulation attempts more difficult
- Dimples complicate illegal copying of keys
- Up to 11 locking elements per cylinder side for an optimal protection against opening attempts

Investment security

- An additional row of pins makes even more complex locking systems and extensions possible
- The option of a later extension offers more extensive adjustment possibilities, for example when the authorization structure changes
- A later extension guarantees a long use of a locking system, for example when a key is lost

Combination with the system KV14 (optional) For highest protection against illegal opening

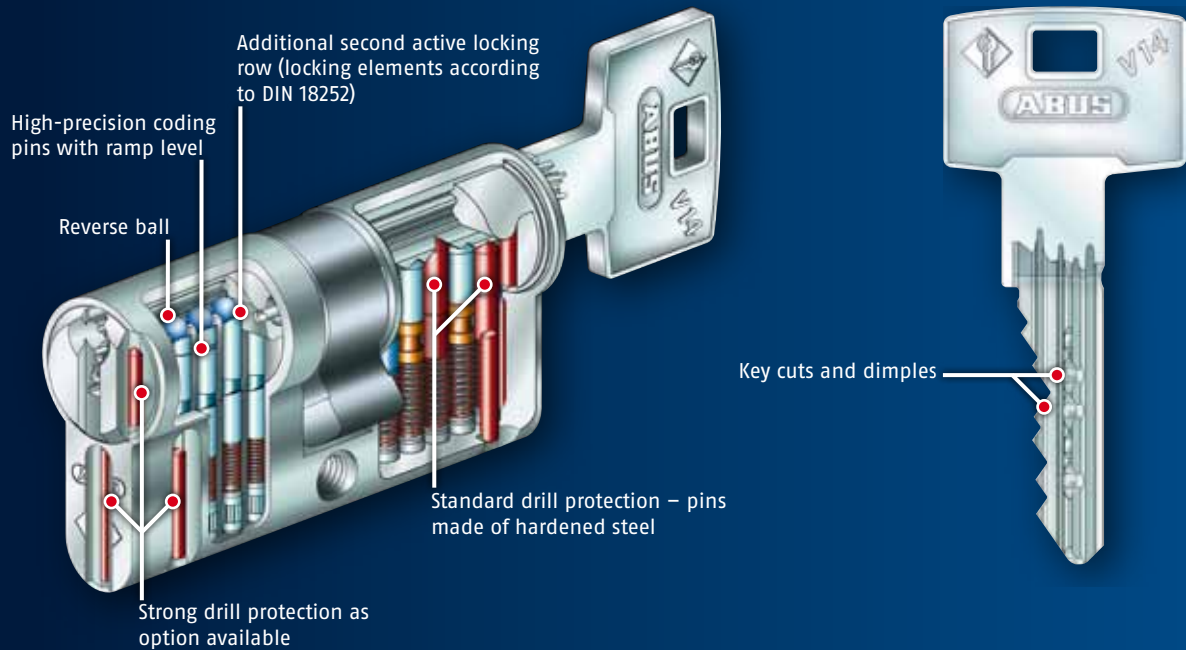

Cylinder illustration with optional drill protection

Complex key systems for highest security demands on VdS level

System KV14 = System V14 + active lateral locking elements (K14)

Highest security does not require a long explanation:

Choose this second spring mounted active locking row for highest security demands. By using this system you meet the insurance demands according to VdS, also in very complex locking systems.

Improved Security

- The second active row of pins makes intelligent manipulation attempts more difficult
- The high-precision coding pins and the precision profile offer an optimal protection against unauthorized key copying
- Up to 11 active locking elements per cylinder side for an optimal protection against opening attempts

Investment security

- An additional row of pins offers even more complex locking systems and extensions
- The option of a later extension with a second row of pins offers more extensive adjustment possibilities, for example when the authorization structure changes
- A later extension offers a long use of a locking system, for example when a key is lost



Security Tech Germany

Security you can trust

With 11 faculties and over 30,000 students the Humboldt University Berlin relies on a locking system of ABUS Pfaffenhain.



Consulting and planning

Structured and thorough planning is the basis of a safe and functional locking system. We are pleased to consult on a suitable locking system that meets your particular requirements. Through our staff and partners we can provide help and assistance either by phone or directly on location.

Please contact us.

Contact

ABUS Pfaffenhain GmbH
Fabrikstraße 1
09387 Jahnsdorf
Germany

www.abus.com
export@abus-pfaffenhain.de

Export Department
Tel.: +49 3 72 96 713-264
Fax: +49 3 72 96 713-754